

From Waste to Resource

Unlocking Critical Minerals from Copper Slag in a Circular Economy



Presenter: Dr Tina Phiri Chanda



CONTENT



Overview on global smelting slag generation



Mineralogical complexity of smelting slag



Linear economy Vs circular economy



Technical path for circular reprocessing



Reprocessing strategies for smelting slag



Integrated process flowsheet



Summary

Decades of Accumulation: The Scale of the Slag Mountain

1

38.6 Million Tonnes

Average annual global production

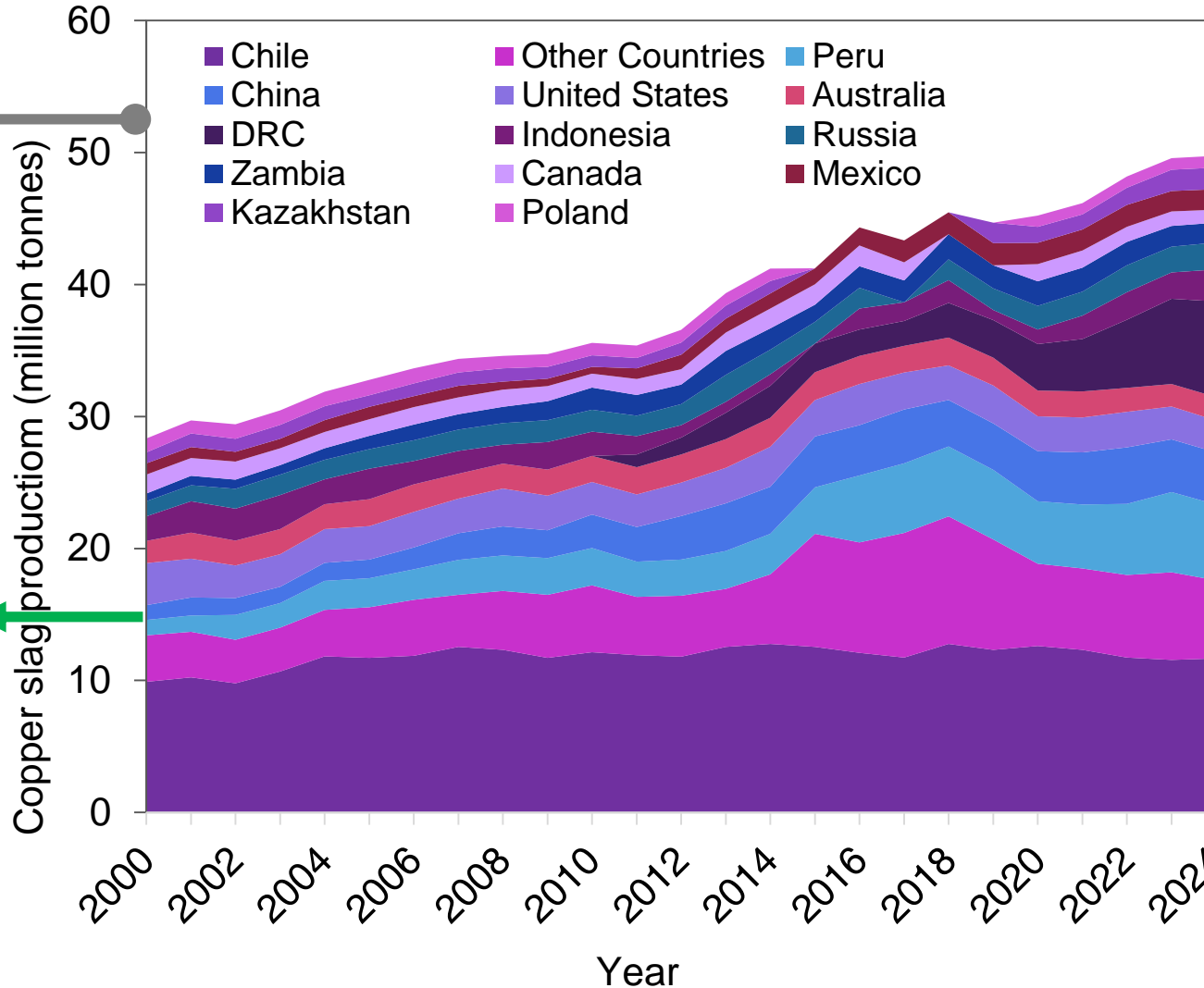

2

966 Million Tonnes

Total slag generated globally over the last 25 years

Reprocessing
increase critical metal supply and reduce environmental impacts

3

The Global Footprint

Concentrated primarily across 13 major mining nations



The Flawed Status Quo: The Linear Economy



Take

The Process

We take materials from the earth, we make products, and we dispose of them

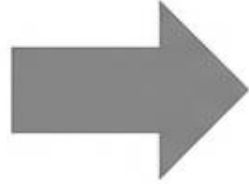

Make

The Core Flaw

This 'Take → Make → Waste' model relies on the dangerous illusion of an infinite supply of resources

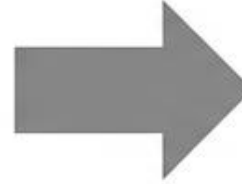

The Result

Mountains of discarded waste

Research background: Challenges of slag processing

Concentrate (CuFeS₂)
+ Silica (SiO₂)

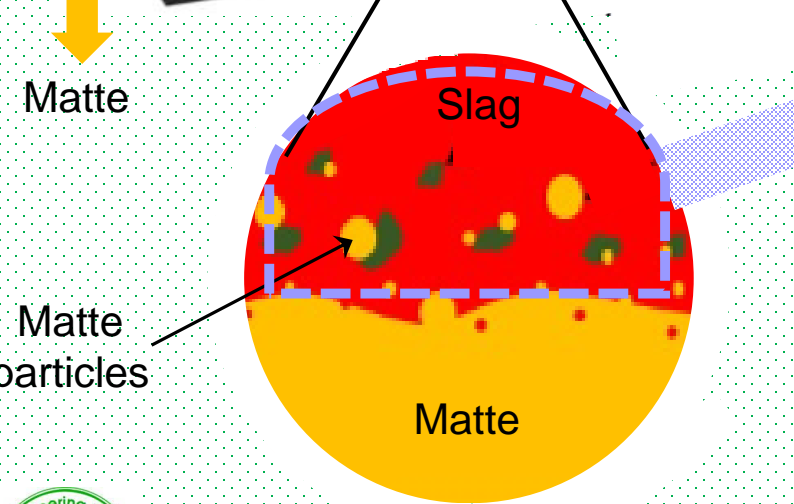
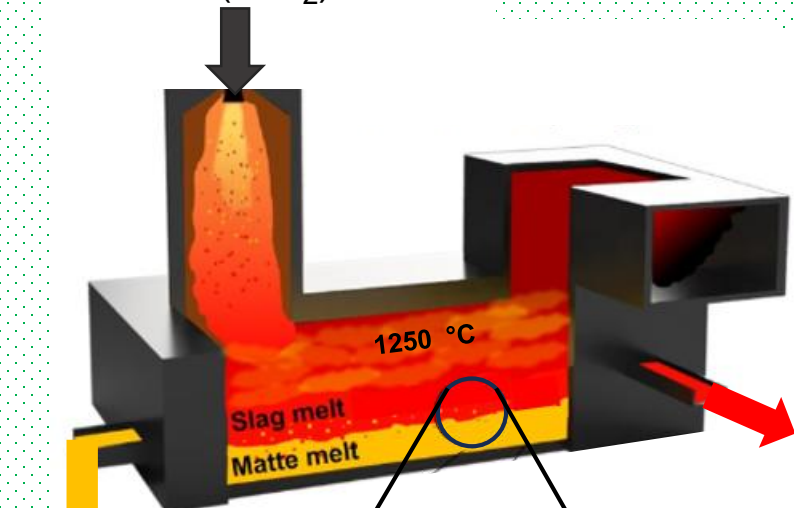
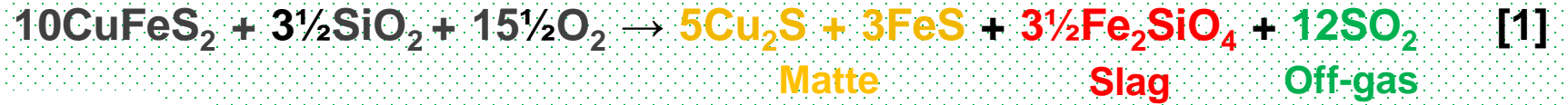

High energy intensive slag processing

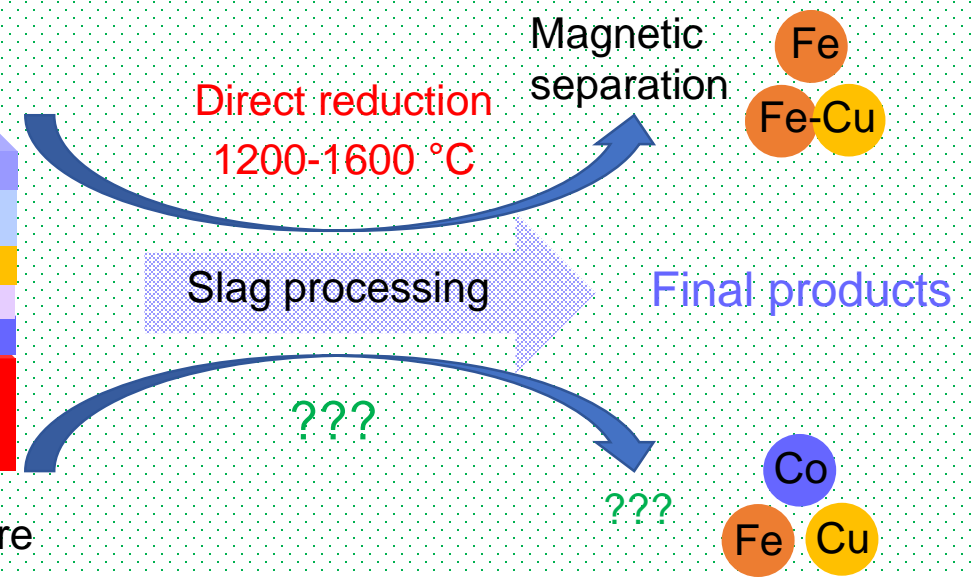
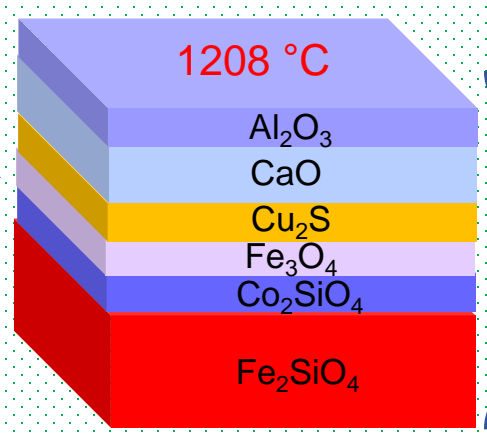

Low energy slag processing technology

➤ Slag viscosity affect matte-slag phase separation



Inside the Matrix: The Mineralogical Challenge

The Matrix

Predominantly Fayalite (Fe_2SiO_4) and Magnetite (Fe_3O_4), intergrown into a highly refractory, coherent mineral network.

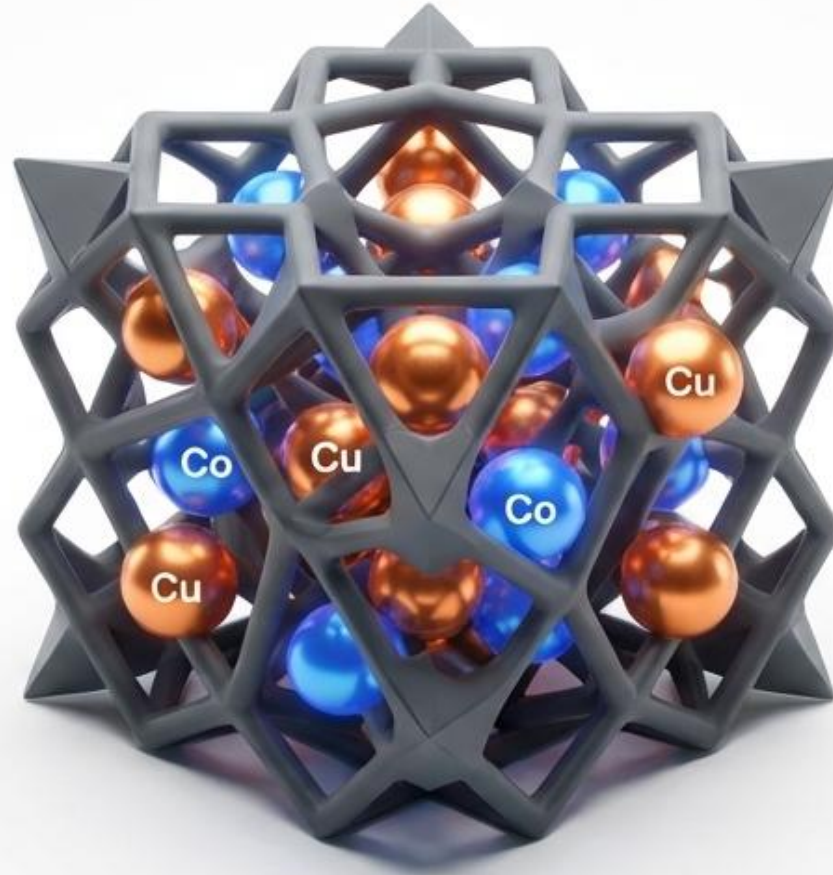

The Trapped Prize

Averages of 1.04% Cu, 0.79% Co, and 25.63% Fe. (Grades that rival or exceed primary ores).

Core Insight: The slag is highly heterogeneous. The critical metals are abundant, but chemically locked away in silicate glassy matrices.

The Three Core Principles of a Circular Economy

Principle 1: Eliminate waste.

Principle 2: Circulate products and materials (at their highest value).

Principle 3: Regenerate nature.



The System View: The Butterfly Diagram

A comprehensive map of material flows. The diagram separates the economy into two distinct halves: The Biological Cycle (left) for consumables, and the Technical Cycle (right) for durables.

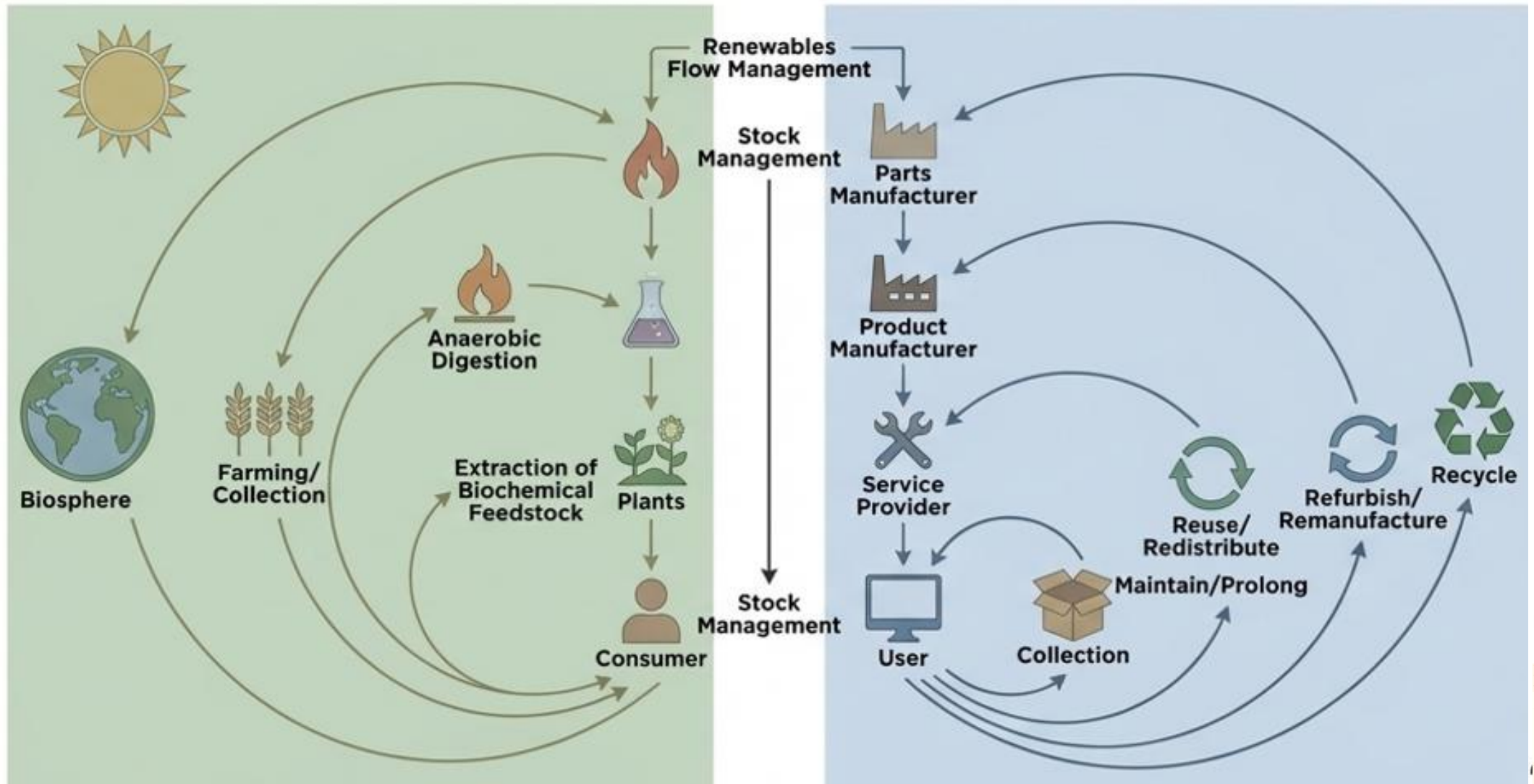

The Biological Cycle: Returning Nutrients

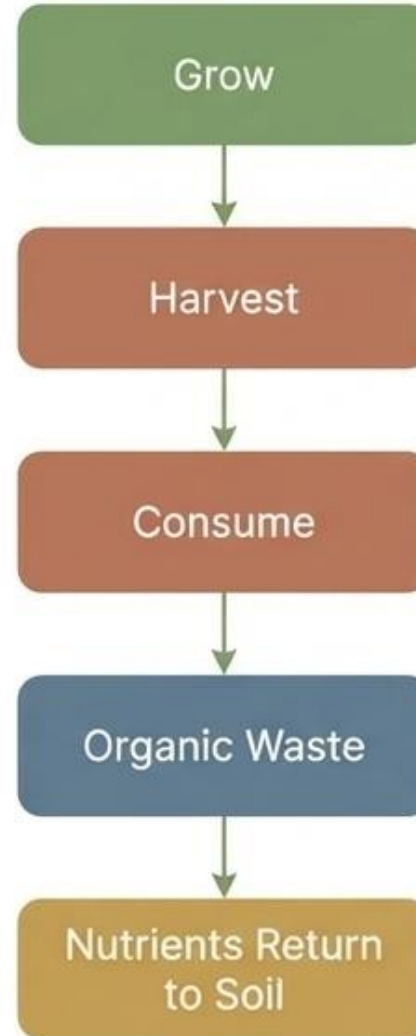
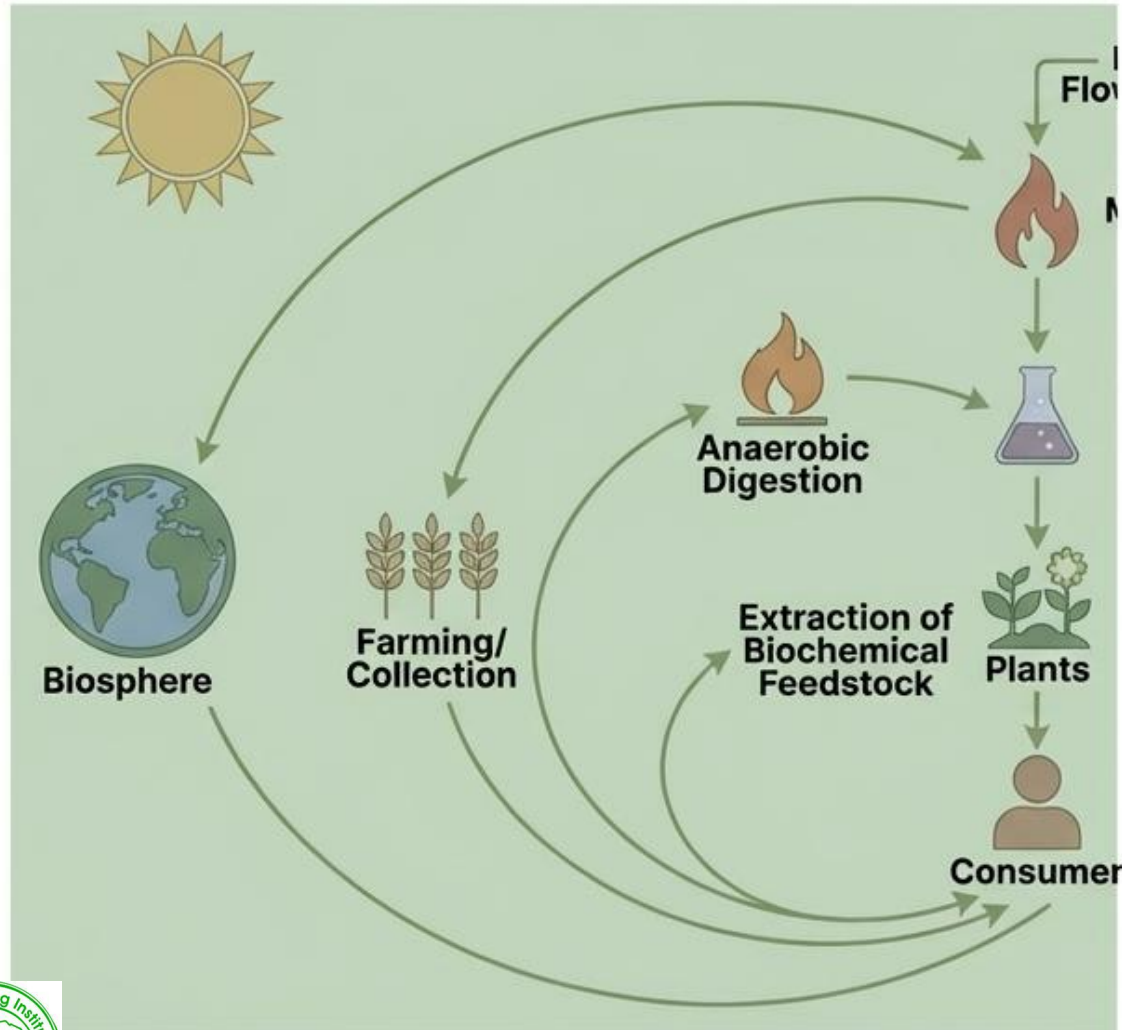

Beyond 'Less Harm'
The focus is not merely doing less harm to the environment, but actively enhancing and regenerating it.

Agriculture's Role
Building biodiversity and resilience to regenerate degraded ecosystems must be central to farming.

The Loop
Food that is grown, harvested, and consumed leaves organic waste. In a CE, these nutrients are returned to the soil rather than left to degrade nature.

The Technical Cycle: Used, Not Consumed

The right side of the diagram governs materials and manufactured products.

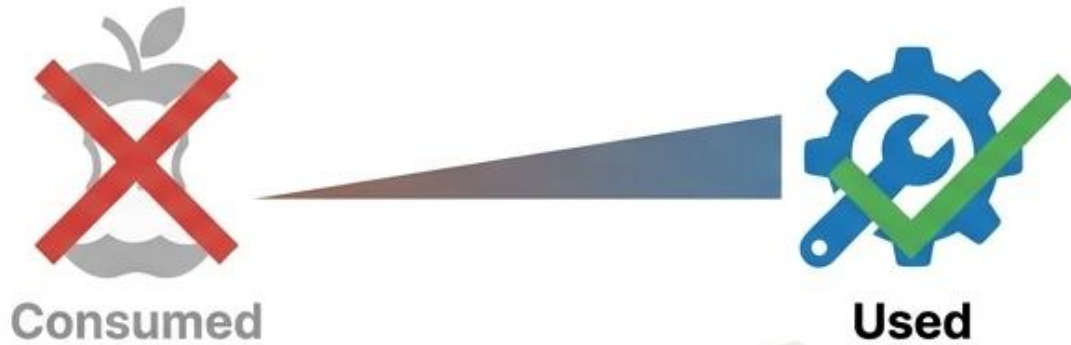

Core Concept: These items are *used* (as opposed to consumed). The cycle provides the engineering pathways to ensure they remain in active use rather than becoming discarded waste.

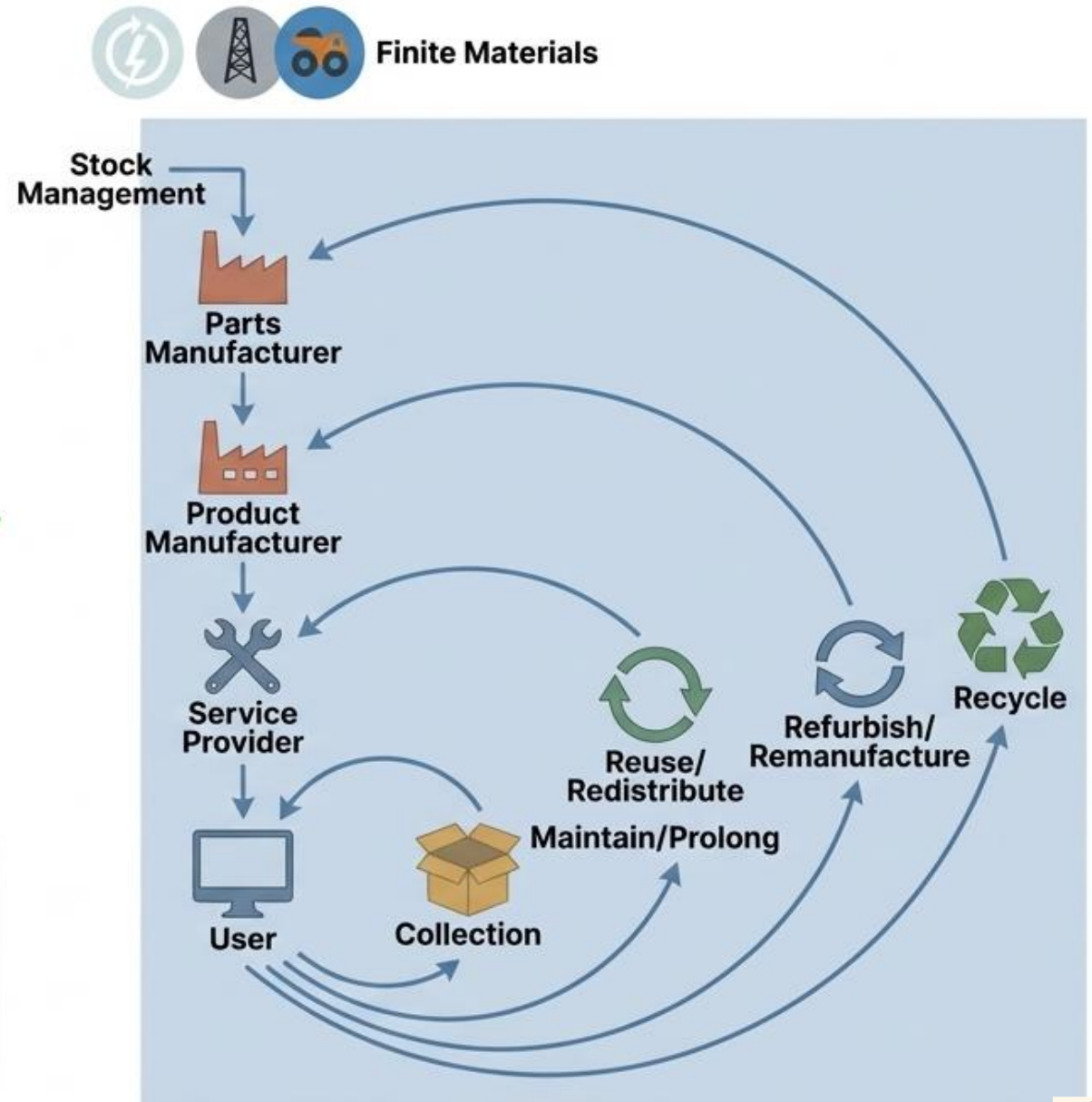

Technical pathways for metal recovery

- **Re-mining:** Waste material requiring an entirely new mining stage prior to re-processing.
- **Reprocessing:** Waste material sent directly through a new processing stage for mineral extraction.

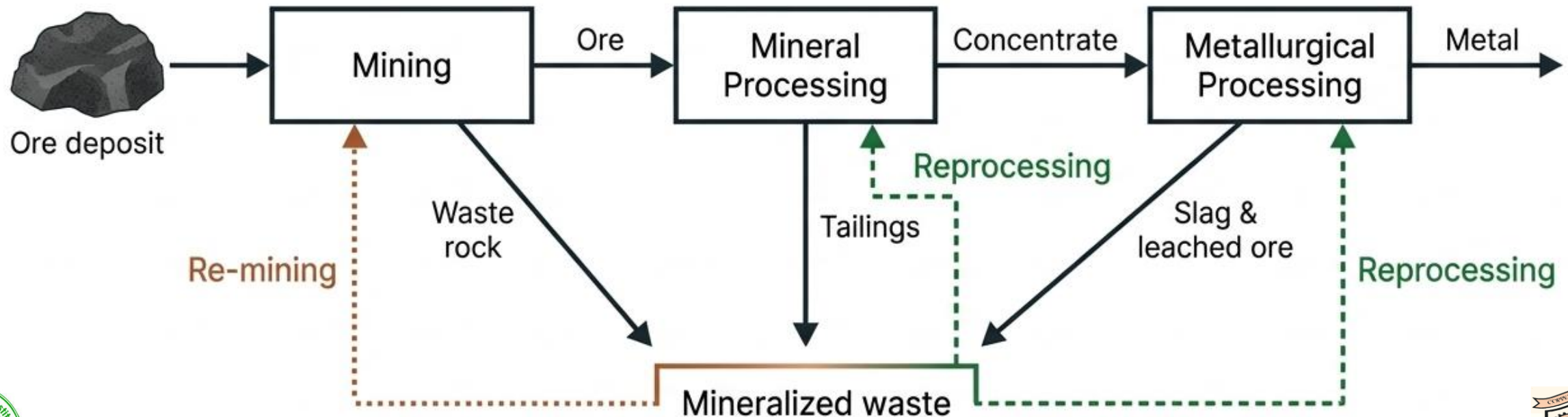

The Reprocessing Arsenal: Four Keys to Unlock the Matrix



Flotation

Physico-chemical separation process based on surface properties.



Hydrometallurgy

Extraction of metals from ores or slag using aqueous solutions.



Pyrometallurgy

Thermal treatment of materials at high temperatures for metal recovery.



Pyro-Hydrometallurgy

Hybrid process combining high-temperature thermal and aqueous methods.



Core Insight: We possess four primary metallurgical pathways to break down the slag. Each comes with distinct operational trade-offs between energy demand, environmental impact, and recovery yield.

1. Flotation: The Traditional Beneficiation Route

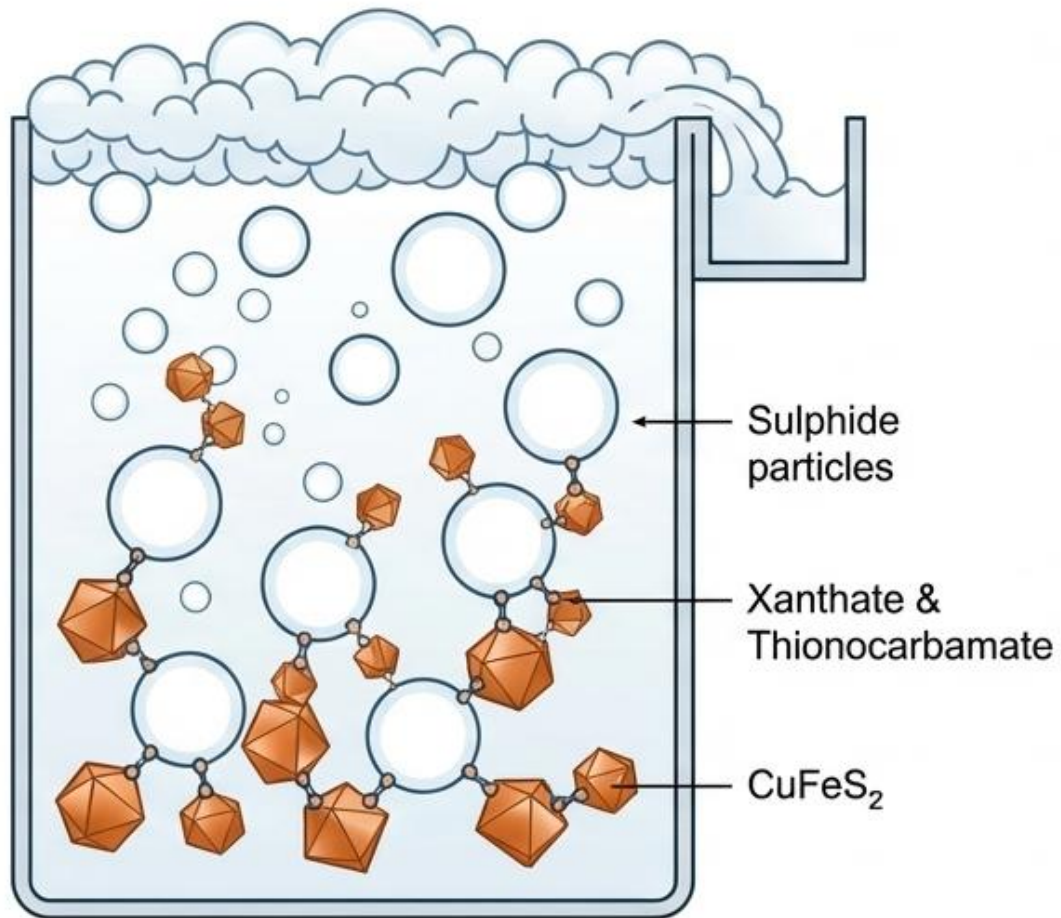

Performance Data:

Achieves 80–87% copper recovery under alkaline conditions (pH 9–11.5).



The Bottleneck:

Highly effective for sulphides, but completely **blind to oxidized copper and cobalt** embedded in the silicate matrix. These oxides have hydrophilic surfaces and require **complex, pre-commercial sulphidation treatments** (e.g., sodium sulphide) to become floatable.

2. Hydrometallurgy: The Low-Energy Liquid Path

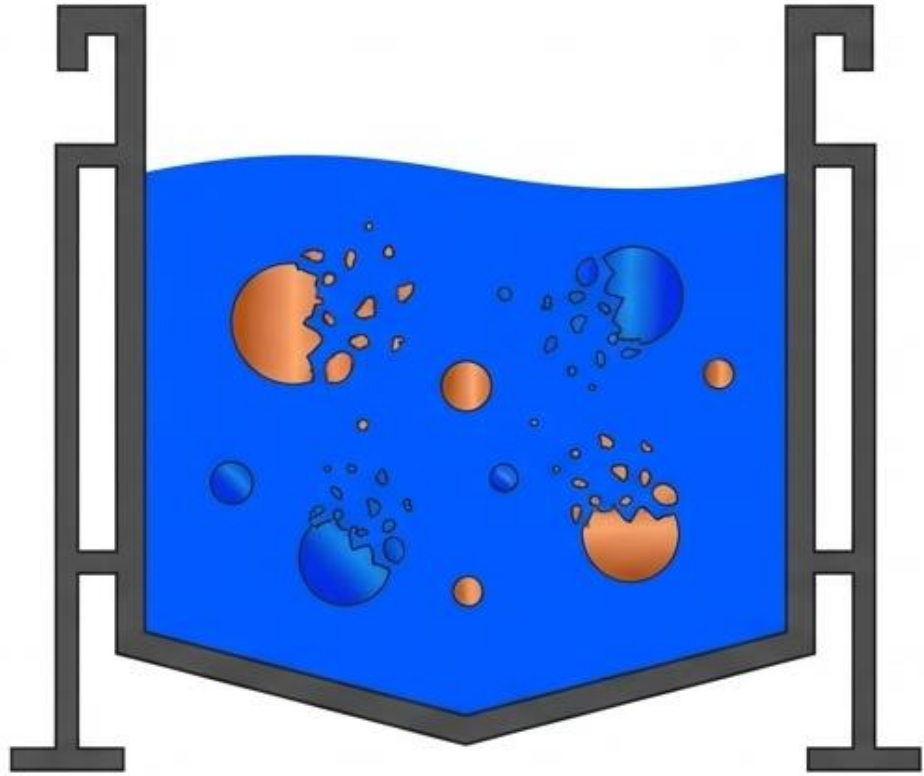

Performance Data:

Exceptional recovery rates utilizing sulphuric acid: up to 98% Co and 89% Cu. Low energy and capital inputs.

The Bottleneck:

Plagued by excessive acid/lime consumption and the formation of silica gel, which ruins solid-liquid separation/filtration.

Emerging Fixes:

Mechanochemical activation, oxidant-assist (H_2O_2), UV-irradiation, and eco-friendly organic lixiviants (glycine, citric acid) are actively solving these limitations.

3. Pyrometallurgy: The Brute Force Approach



Performance Data:

Outstanding yield. Carbothermal reduction converts slag minerals into metallic phases, achieving 95.7% Co and 90% Cu recovery.

The Catch:

Extreme thermal requirements (>1,200 Degrees Celsius) to melt the refractory fayalite. This results in massive energy consumption, high CO₂ and SO₂ emissions, and the dangerous volatilization of trace toxic metals (As, Pb, Zn, Cd).



4. Pyro-Hydrometallurgy: The Optimized Hybrid



Performance Data:

Highly efficient extraction: 83.8% Cu and 84.8% Co.

The Strategic Advantage:

Reduces thermal energy demand by 30–50% compared to conventional smelting (>1200 Degrees Celsius), significantly improving the energy-to-yield ratio and lowering CO₂ emissions while bypassing the extreme silica gel issues of pure hydrometallurgy.

Hypothetical flowsheets for reprocessing of slag

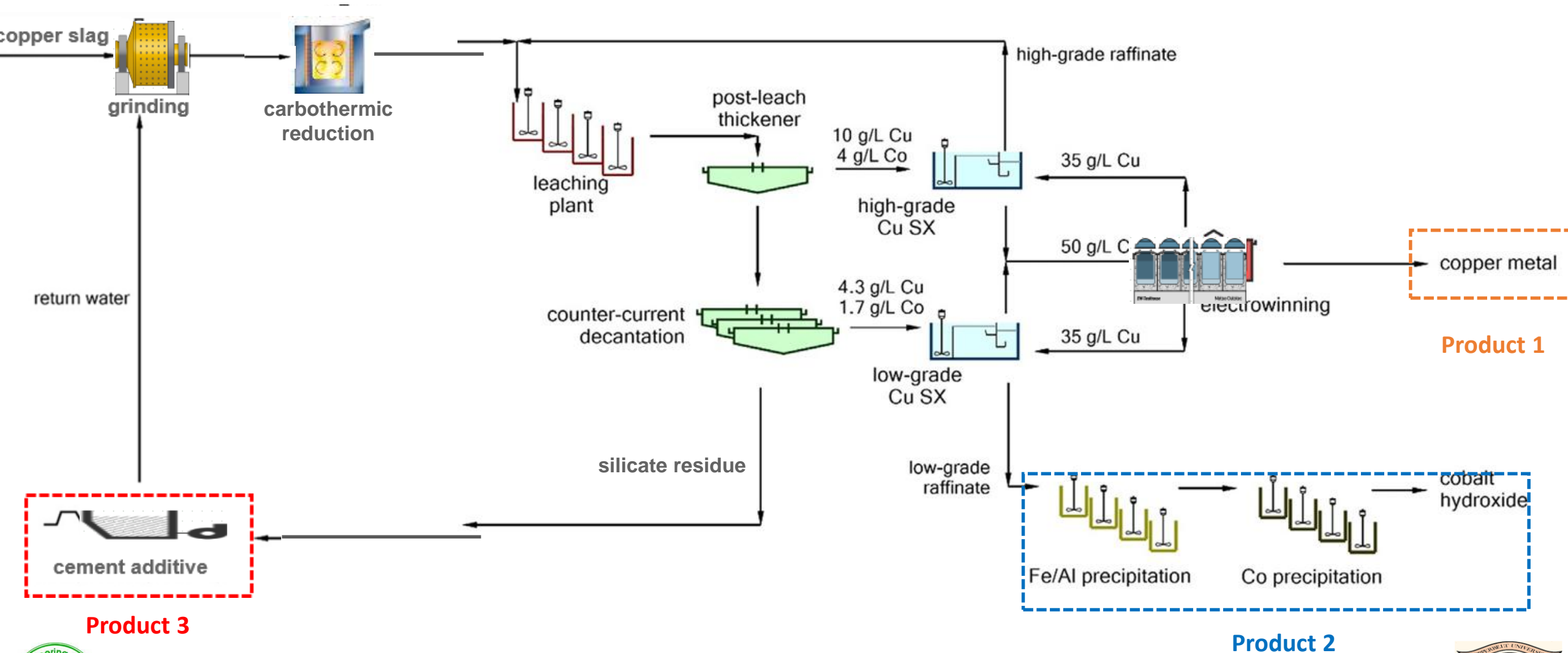
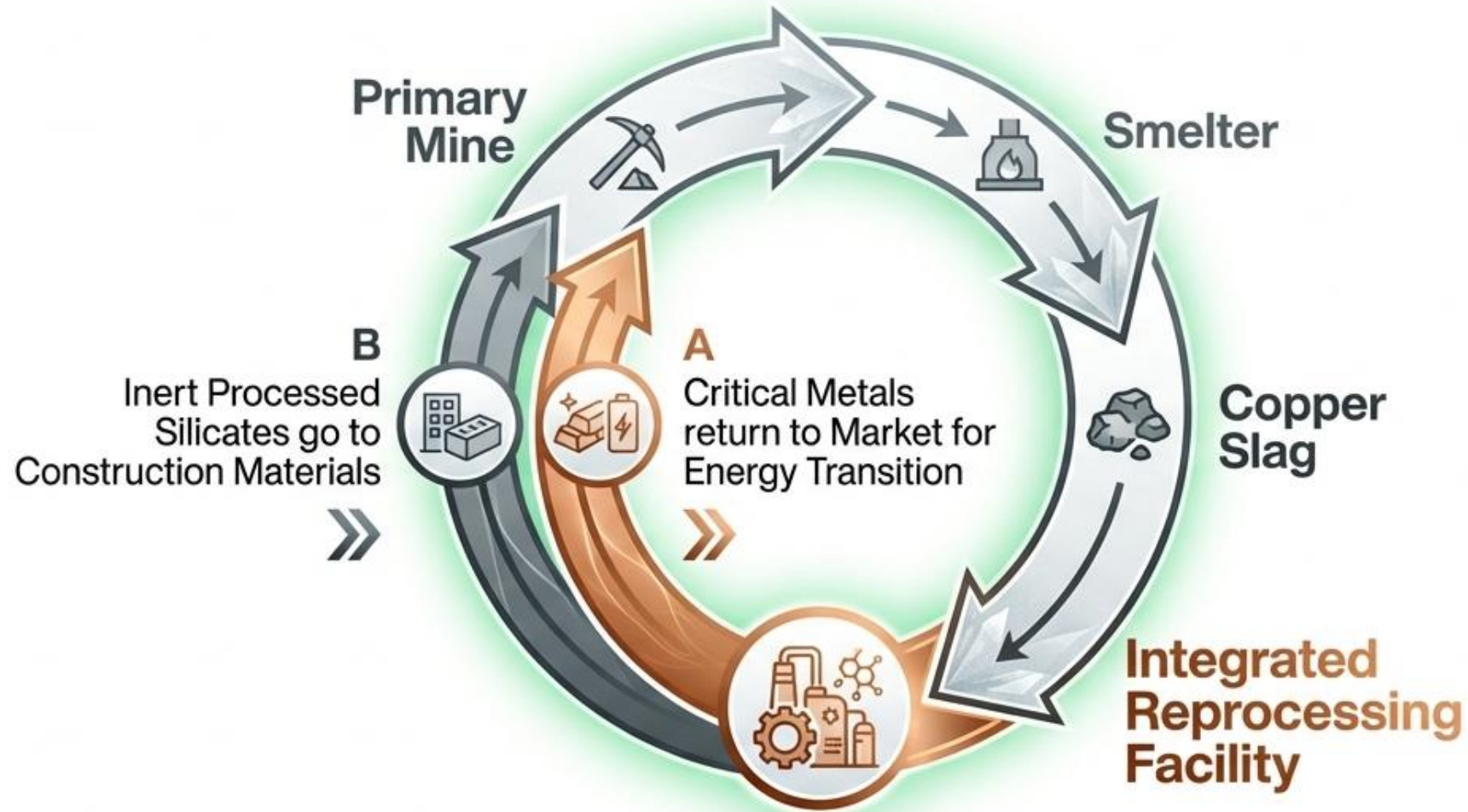

Figure 14. A schematic diagram carbocatalytic-acidic leach process flowsheet for industrial application

Paradigm Shift: The Circular Economy Model



Core Insight: True circularity acknowledges thermodynamic limits but drastically improves material efficiency. We extract the vital metals for decarbonization, and repurpose the benign, leftover silicate matrix for cement and road base, resulting in zero terminal waste.



Bridging the Gap to Commercialization

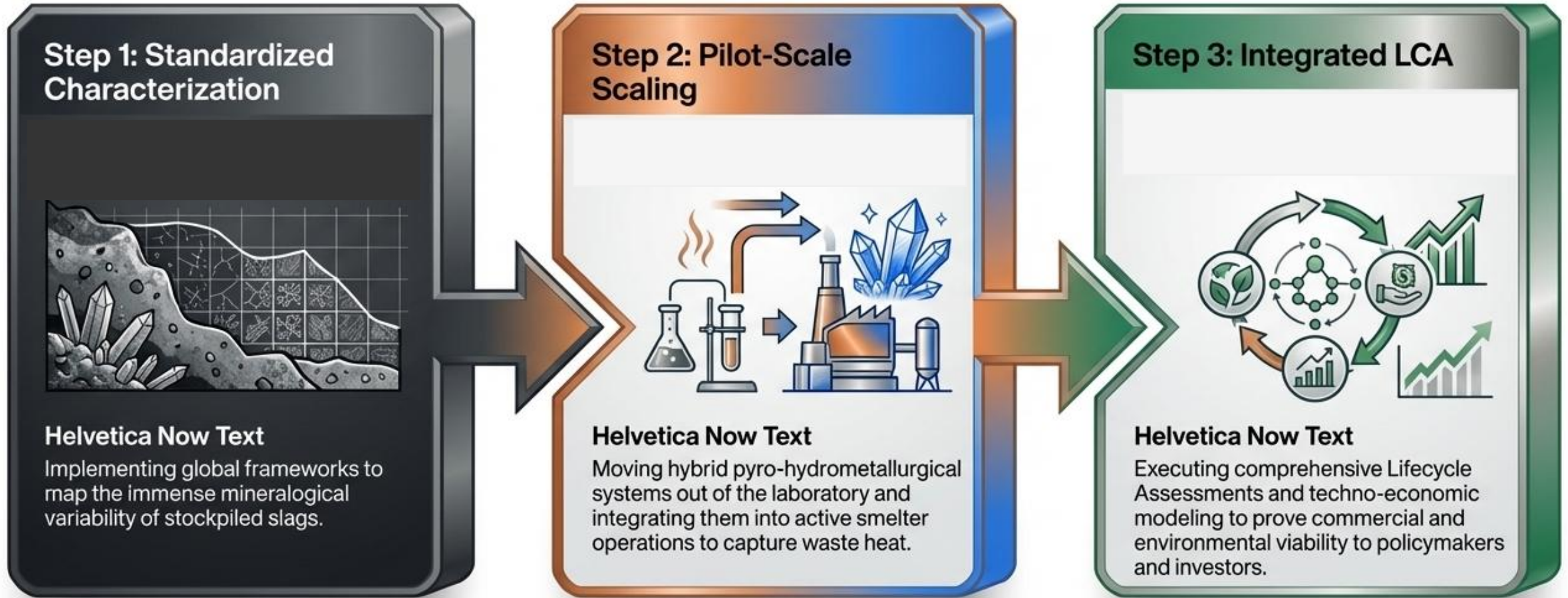

Three Pillars of Circular Value



Resource Efficiency

Supplements primary mining operations with high-grade secondary supply, reducing pressure on declining natural deposits.



Emissions Reduction

Leverages existing smelter infrastructure, yielding a drastically lower CO2 and energy footprint compared to processing virgin ores.



Environmental Remediation

Dual valorization eliminates the toxic leaching risks of legacy stockpiles while creating valuable, inert by-products for the construction industry.

A Strategic Reserve, Not a Liability



Copper slag must no longer be managed as a terminal liability. It is a massive, pre-mined strategic reserve waiting to power the global energy transition.



The End

THANK YOU FOR YOUR ATTENTION!

